



Rope Pull Emergency Stop Switches

RP-LS42F-75L.. Series 42 mm Latching Switches with Rope Actuators



Features

-  Positive-opening safety contacts (IEC 60947-5-1), not dependent upon springs
- Contacts latch open when rope is pulled; requires manual reset
- Heavy-duty thermoplastic housing, rated IP67 and NEMA 4, suitable for demanding industrial environments
- Innovative design provides quick, easy rope fixing and tensioning on models RP-LS42F-75LE and RP-LS42F-75LF
- Rope spans up to 75 m (245')
- Both safety contacts are closed with normal rope tension, and open when rope is pulled or if rope breaks (or if tension is reduced from normal amount)
- Extra contacts for monitoring or to provide dual-channel input to a safety module
- Indicator mark on switch shows when rope has proper tension for operation
- Long life, switch rated at 1 million mechanical operations, minimum
- Three available models: one with E-stop button, all with latching outputs
-  Insulated device (IEC 60947-5-1) on all models with plastic housings



Rope Pull Emergency Stop Switches – RP-LS42F-75L.. Series



Important Information

Regarding the Use of Rope Pull Emergency Stop Switches

In the United States, the functions that Banner rope pull emergency stop switches are intended to perform are regulated by the Occupational Safety and Health Administration (OSHA). Whether or not any particular rope pull switch installation meets all applicable OSHA requirements depends upon factors that are beyond the control of Banner Engineering Corp. These factors include the details of how the switches are applied, installed, wired, operated, and maintained.

Banner Engineering Corp. has attempted to provide complete application, installation, operation, and maintenance instructions. This information is found in the instruction manual packaged with each rope pull switch. Direct any questions regarding the use or installation of rope pull switches to the factory applications department at the telephone numbers or address shown below.

Banner Engineering Corp. recommends that rope pull emergency stop switches be applied according to the guidelines set forth in standards listed below. In addition, the user of Banner rope pull switches has the responsibility to ensure that all local, state, and national laws, rules, codes, and regulations relating to the use of Banner rope pull switches in any particular application are satisfied. Extreme care is urged that all legal requirements have been met and that all installations and maintenance instructions are followed.

Application Assistance

Toll Free: 1-888-3-SENSOR (1-888-373-6767)
Email: sensors@bannerengineering.com
Address: 9714 Tenth Avenue North
Minneapolis, MN 55441

U. S. Standards Applicable to Use of Emergency Stop Safety Modules



ANSI B11	Standards for Machine Tools "Safety Requirements for the Construction, Care and Use" Available from: Safety Director AMT—The Association for Manufacturing Technology 7901 Westpark Drive McLean, VA 22102 Tel.: 703-893-2900
NFPA79	"Electrical Standard for Industrial Machinery (1997)" Available from: National Fire Protection Association 1 Batterymarch Park, P.O. Box 9101 Quincy, MA 02269-9101 Tel.: 800-344-3555
ANSI/RIA R15.06	"Safety Requirements for Industrial Robots and Robot Systems" Available from: Robotic Industries Association 900 Victors Way, P.O. Box 3724 Ann Arbor, MI 48106 Tel.: 734-994-6088

European Standards Applicable to Use of Emergency Stop Safety Modules

ISO/TR12100-1&-2 (EN 292-1 & -2)	"Safety of Machinery—Basic Concepts, General Principles for Design Part 1: Basic Terminology, Methodology"; Part 2: Technical Principles and Specifications
ISO13849-1 (EN 954-1)	"Safety of Machines—Safety Related Parts of Control Systems"
IEC/EN 60204-1	"Electrical Equipment of Machines: Part 1: General Requirements" Also, request a type "C" standard for your specific machinery.
ISO13850 (EN 418)	"Safety of Machinery—Emergency Stop Equipment Functional Aspects, Principles for Design"
IEC 60947-5-5	"Electrical Emergency Stop Devices with Mechanical Latching Function" Available from: Global Engineering Documents 15 Inverness Way East Englewood, CO 80112-5704 Tel.: 800-854-7179

Rope Pull Emergency Stop Switches – RP-LS42F-75L.. Series

Models

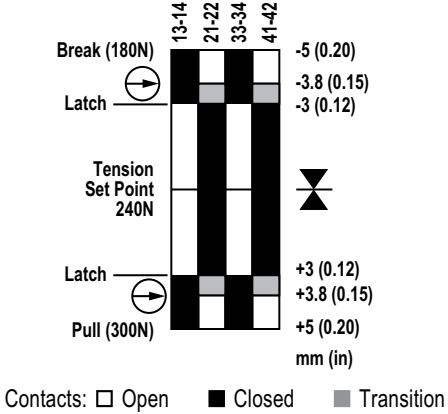
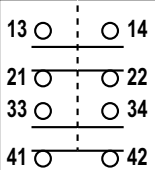
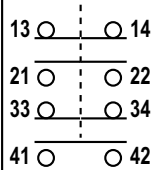
Model†	E-Stop	Built-in Turnbuckle	Run Position	Cable Pulled/ Cable Break	Switching Diagram
RP-LS42F-75L	No	No			
RP-LS42F-75LE	Yes	Yes			
RP-LS42F-75LF	No	Yes			

NOTE:  This symbol for a positive-opening safety contact (IEC 60947-5-1) is used in the switching diagram to identify the point in actuator travel where the normally-closed safety contact is fully open.



WARNING ... Not a Safeguarding Device

An Emergency Stop Device, including, but not limited to buttons, rope pulls and cable pulls, is not generally considered a safeguard; and does not alone fulfill U.S. or International requirements for safeguarding hazards associated with machinery.

The definition of safeguarding is the "protective measure using safeguards [guards or protective devices] to protect persons from the hazards which cannot reasonably be eliminated..." (ISO12100-1, 3.29 and 3.30).

A safeguard limits or eliminates an individual's exposure to a hazard (examples include interlocking devices, safety mats, safety light screens). An emergency stop is considered to be a complementary protective measure, which is neither an inherently safe design measure, nor safeguarding, but may be required as part of the safety related control system and risk reduction strategy (ISO12100-2, 4.5.1 and 4.5.2).

The user must refer to the relevant standard(s) to determine the safeguarding requirements for their particular situation.

Overview

Models RP-LS42F-75L.. are rope pull emergency stop switches in compact, limit switch-style housings made of high-impact thermoplast. When used with steel wire rope, they can provide emergency stop actuation along conveyors and similar machinery. Red PVC-covered 3 mm diameter wire rope is recommended (see page 10).

The switches have redundant contacts; terminals 21/22 and 41/42 are positive opening when there is a cable-pull or cable-brake situation. When used separately, these contacts provide inputs to a dual-channel safety module (see Figure 6). Terminals 21/22 and 41/42 can also be used individually to provide single-channel switching or as a single-channel input to a safety module. Terminals 13/14 and 33/34 are for monitoring purposes only (closed in a cable-brake/-pull situation).

When the rope is properly tensioned (240N), the red arrows are centered on the hash mark on the tension indicator window, the contacts at terminals 21/22 and 41/42 are closed, and the contacts at terminals 13/14 and 33/34 are opened (see Figures 1, 2 and 4).

These rope pull emergency stop switches are not generally considered safeguarding devices, in that they do not prevent or reduce exposure of individuals to a hazard. They provide the same function as other types of emergency stop switches.

All models feature "latching" operation. When the rope is pulled, the switch contacts 21/22 and 41/42 open and remain open until the built-in reset button is manually reset (see Figure 1).

Rope Pull Emergency Stop Switches – RP-LS42F-75L.. Series

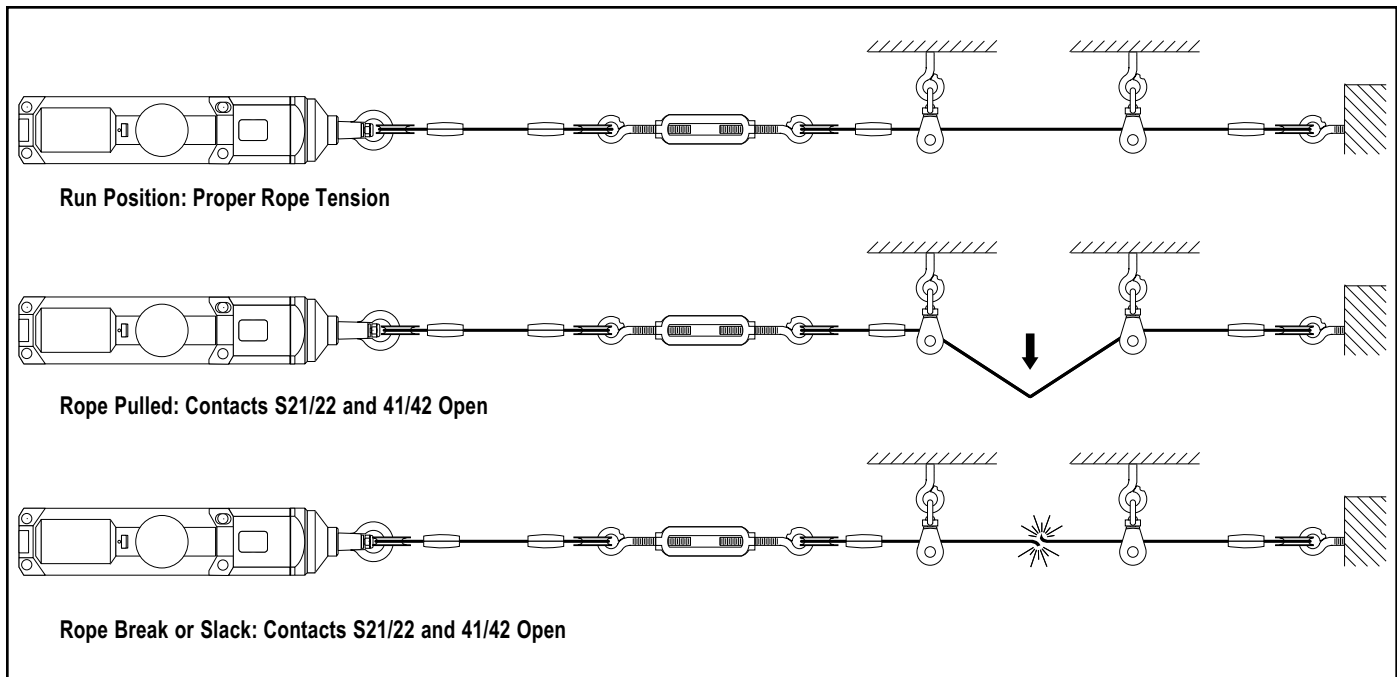

Figure 1. Run, rope pulled, and rope break switch positions

Mechanical Installation

Installation Guidelines

- The wire rope should be easily accessible and visible along its entire length. Markers or flags may be fixed on the rope to increase its visibility.
- Mounting points, including support points, must be rigid.
- The rope should be free of friction at all supports. Pulleys are recommended.
- Use only pulleys (not eye bolts) when routing the rope around a corner, or whenever direction is changed, even slightly.
- Never run rope through conduit or other tubing.
- Never attach weights to the rope.
- Temperature affects rope tension. The rope expands (lengthens) when temperature increases, and contracts (shrinks) when temperature decreases. Significant temperature variations require frequent checks of the tension adjustment.
- Do not exceed the maximum total rope length, as specified in Figure 3. Banner offers models for greater spans; contact the factory or visit www.bannerengineering.com for model selection.

Installation Procedure

1. Mount the switch securely on a solid, stationary surface.
2. Fasten an eye bolt at the opposite end of the rope span, up to 75 m (245') from the switch. The anchor for the eye bolt also must be solid and stationary, to withstand the constant tension and possible pull of the rope.
3. Assemble the rope, as shown in Figure 3. Keep the rope's PVC cover intact along its complete length.
4. Use pulleys (recommended) or eye bolts at each support point. A pulley must be used when routing the rope around a corner, regardless of the angle.

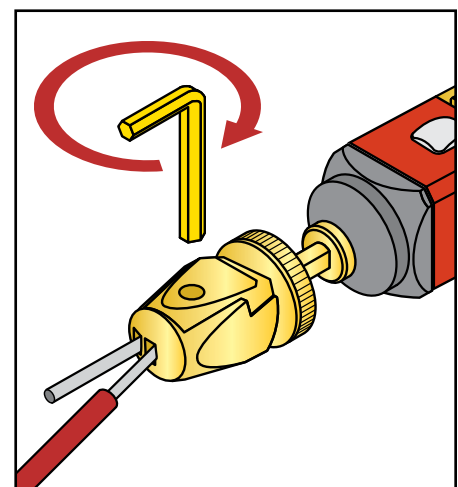

Figure 2. Tightening the rope into the internal turnbuckle (models RP-LS42F-75LE and RP-LS42F-75LF)

Rope Pull Emergency Stop Switches – RP-LS42F-75L.. Series

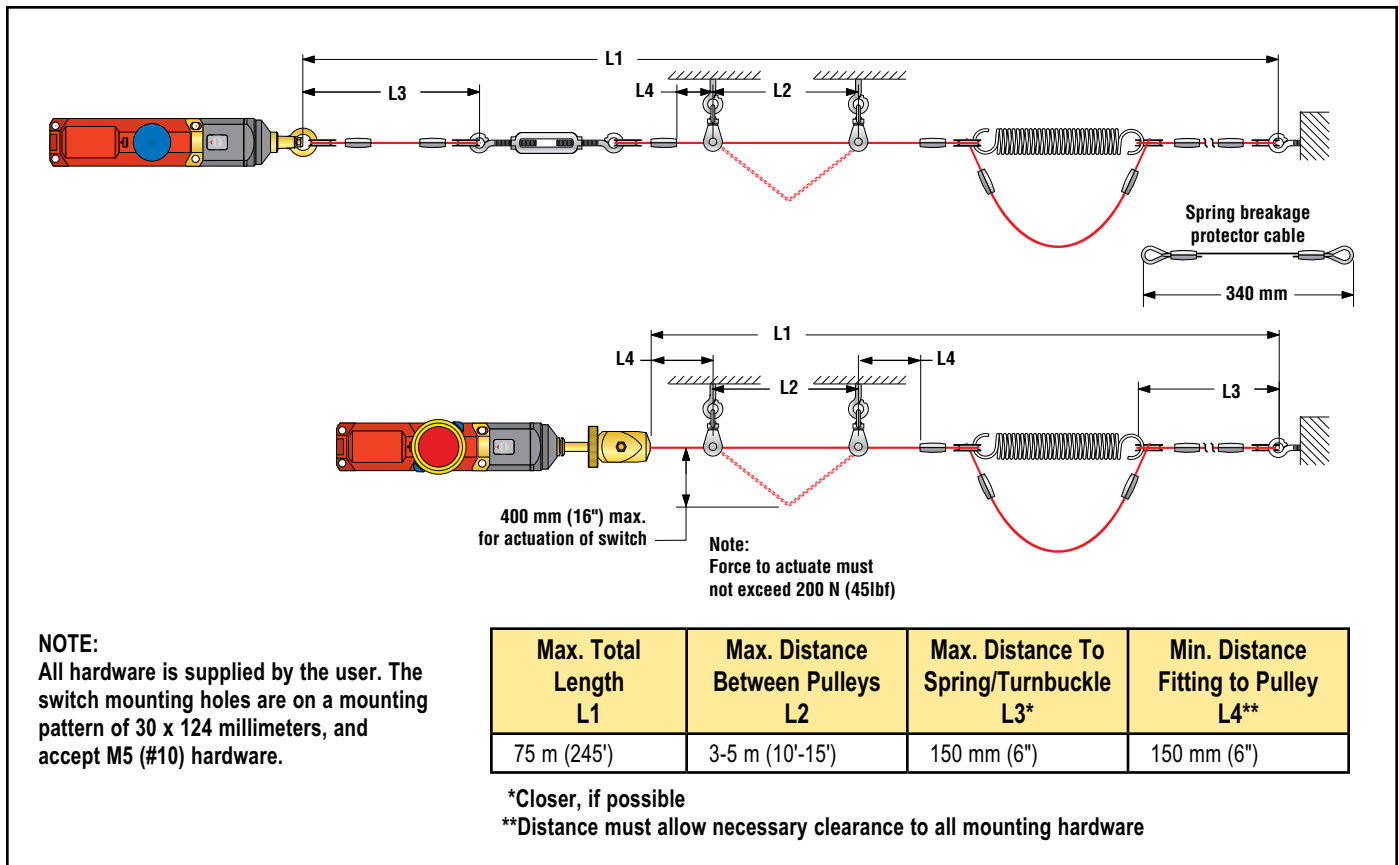

Figure 3. Assembly of rope and hardware (rope span components are listed on page 10)

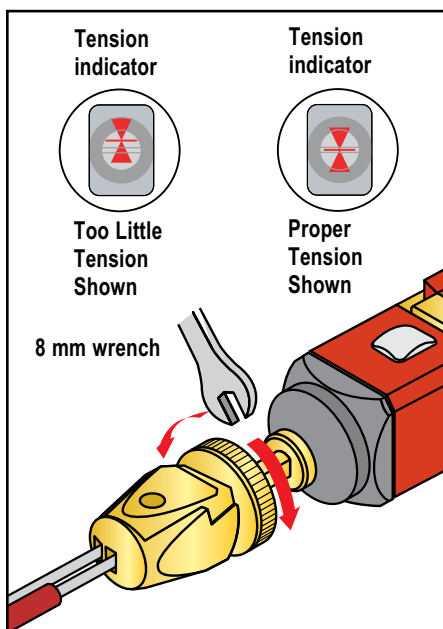

Figure 4. Applying tension to the rope (models RP-LS42F-75LE and RP-LS42F-75LF)

Installing Model RP-LS42F-75LE or RP-LS42F-75LF

These models have their own internal turnbuckle and clamp to tension the rope and to hold it in place. This innovative design provides for quick and easy rope fixing and tensioning, and means no external turnbuckle is required, nor is any additional clamp required at the switch end of the rope.

To install the rope at the switch end, strip away several inches of the cable covering, as shown in Figure 2. Loosen the set screw on the switch fitting, using a 4 mm hex wrench. Insert the cable into the center hole, and pull the cut end out from the side hole. When the tension is correct, tighten the set screw to hold the rope firmly in place.

Tensioning the Rope

After the rope span components are installed, apply tension to the rope until the arrows in the tensioning indicator are centered on the line in the indicator window (see Figure 4). This indicates sufficient rope tension. (Contacts 21/22 and 41/42 will close.)

Model RP-LS42F-75L: Turn the turnbuckle until the arrows are centered.

Models RP-LS42F-75LE

and RP-LS42F-75LF: Turn the shaft of the switch using an 8 mm wrench as shown in Figure 4, until the arrows are centered.

Pull hard on the rope and reset the latch several times. If the arrows in the tensioning indicator window do not return to the correct position (centered on the line in the window), further tighten or loosen the rope tension as needed until proper tension is shown after such a reset.

Rope Pull Emergency Stop Switches – RP-LS42F-75L.. Series

Electrical Installation

Access to Wiring Chamber

The wiring chamber is accessed via the hinged door. Simply insert a flat-blade screwdriver, as shown in Figure 5, and pry gently down to open. Select the best wiring entrance and thread in the ½" x 14 NPSM conduit adapter (supplied), or the optional M20 x 1.5 cable gland (page 11). The switch knockout will break loose with the final turn of the conduit adapter or cable gland.

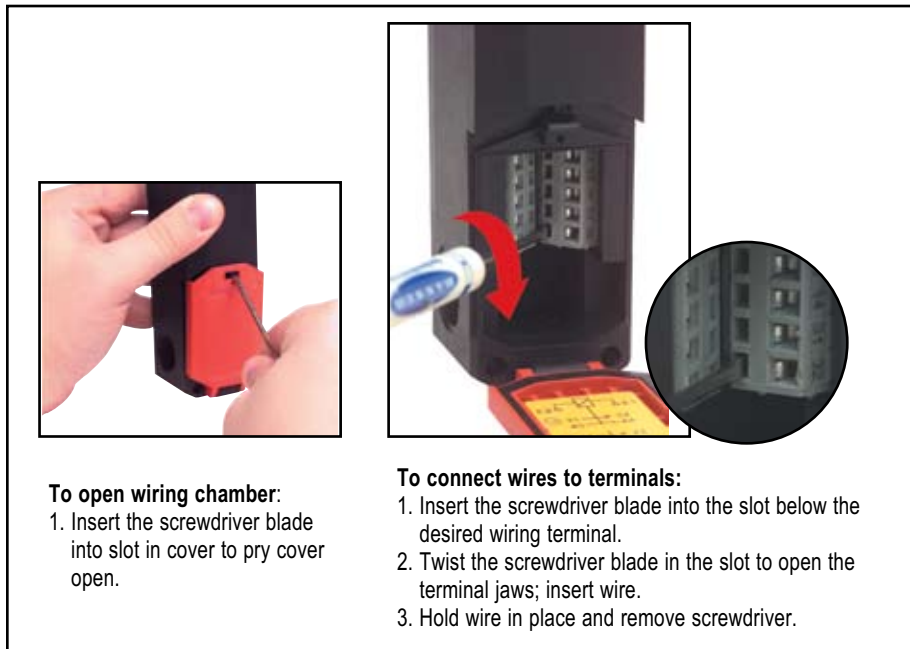

Figure 5. Access to wiring chamber – use a small flat-blade screwdriver

Wiring

These switch models have redundant pairs of safety contacts, so they may be wired for either single-channel or dual-channel output to a safety module or E-stop circuit. Monitor contacts, in either case, may be wired as desired to an external alarm device.

Single-Channel Output: Wire contacts 21/22 or 41/42 together to the input of a safety module or E-stop circuit.

Dual-Channel Output: Wire contacts 21/22 and 41/42 independently to the two safety module inputs (see Figure 6).

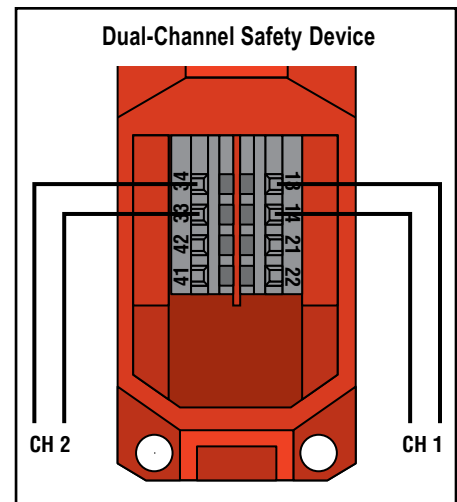

Figure 6. Wire the two switch contacts in series

Rope Pull Emergency Stop Switches – RP-LS42F-75L.. Series

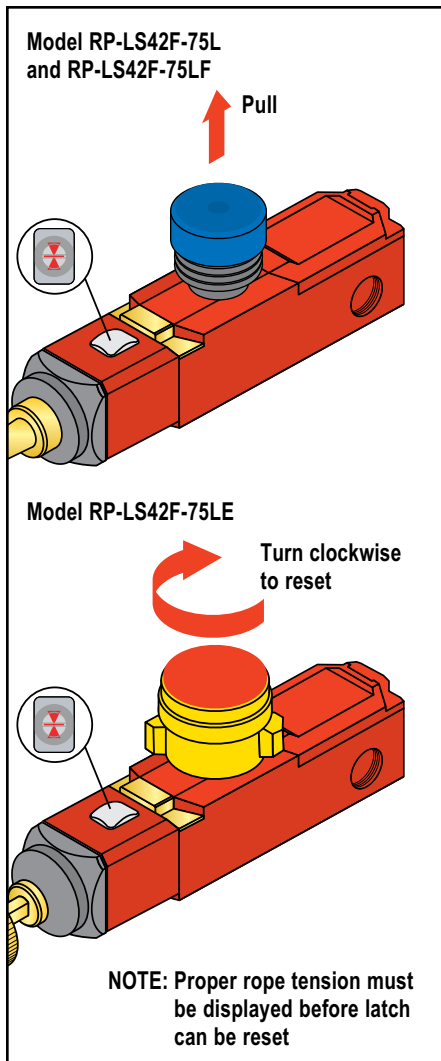

Figure 7. Resetting the latch

E-Stop Reset

E-Stop and Latch Reset

Following the pulling of the rope or the pressing of the E-stop button (model RP-LS42F-75LE), the latch must be reset. The procedure differs slightly between the two models. See Figure 6.

Models RP-LS42F-75L and RP-LS42F-75LF: Pull the blue reset button; the arrows should then be centered in the tensioning indicator window.

Model RP-LS42F-75LE: The E-stop can be reset only when proper tension is indicated. Turn the yellow knob clockwise until the blue arrow is in the “1” position (indicating that the latch has been reset). The latch should make an audible click when reset.

Maintenance

Each rope pull emergency stop installation should be tested for proper machine shutdown response at each shift change or machine setup by a *Designated Person**. In addition, a *Qualified Person** should check for proper rope tension, and adjust as needed, on a periodic schedule determined by the user, based upon severity of the operating environment and the frequency of switch actuations.

The pulleys and other moving parts associated with the rope should be periodically lubricated. If inspection reveals dirt on the rope pull switch or rope assembly, the dirt must be cleaned off and its cause must be eliminated. Replace the rope pull switch and/or rope assembly when any parts (including contacts) or assemblies are found to be damaged, broken, deformed, or badly worn.

The rope pull switch and rope assembly should be replaced at specified intervals based upon the environment and operating conditions. Replacement of the rope pull switch and rope assembly should be considered after no more than 500,000 operations. Always test the control system for proper functioning under machine control conditions after maintenance or replacement of the rope pull switch.



* A *Designated Person* is identified in writing by the employer as being appropriately trained to perform a specified checkout procedure. A *Qualified Person* possesses a recognized degree or certificate or has extensive knowledge, training, and experience to be able to solve problems relating to the emergency stop rope pull switch installation.

Repairs

Banner rope pull emergency stop switches have no field-replaceable components. Contact the Banner Factory Application Engineering Group at the address or the numbers listed at the bottom of the back page. They will issue an RMA (Return Merchandise Authorization) number for your paperwork, and give you the proper shipping address.

Rope Pull Emergency Stop Switches – RP-LS42F-75L.. Series

Specifications

Contact Rating	10A @ 24V ac, 10A @ 110V ac, 6A @ 230V ac 6A @ 24V dc 2.5 kV max. transient tolerance NEMA A300 P300																	
European Rating	Utilization categories: AC15 and DC13 $U_i = 500V$ ac $I_{th} = 10A$	<table border="1"> <thead> <tr> <th colspan="3">40-60 Hz</th> </tr> <tr> <th>U_e V</th> <th>$I_e/AC-15$ A</th> <th>$I_e/DC-13$ A</th> </tr> </thead> <tbody> <tr> <td>24</td> <td>10</td> <td>6</td> </tr> <tr> <td>110</td> <td>10</td> <td>1</td> </tr> <tr> <td>230</td> <td>6</td> <td>0.4</td> </tr> </tbody> </table>		40-60 Hz			U_e V	$I_e/AC-15$ A	$I_e/DC-13$ A	24	10	6	110	10	1	230	6	0.4
40-60 Hz																		
U_e V	$I_e/AC-15$ A	$I_e/DC-13$ A																
24	10	6																
110	10	1																
230	6	0.4																
Contact Material	Silver-nickel alloy																	
Maximum Switching Speed	50 operations per minute																	
Recommended Rope Size	3 mm diameter steel rope (See Accessories, p. 10)																	
Maximum Rope Pull Length	75 m (245')																	
Short Circuit Protection	10 amp Slow Blow, 15 amp Fast Blow. Recommended external fusing or overload protection.																	
Mechanical Life	1 million operations																	
Wire Connections	Screw terminals with pressure plates accept the following wire sizes – Stranded and solid: 20 AWG (0.5 mm ²) to 16 AWG (1.5 mm ²) for one wire Stranded: 20 AWG (0.5 mm ²) to 18 AWG (1.0 mm ²) for two wires																	
Cable Entry	M20 x 1.5 threaded entrance Adapter supplied to convert M20 x 1.5 to ½" - 14 NPT threaded entrance																	
Construction	High-impact thermoplastic housing; zinc die-cast actuator																	
Environmental Rating	NEMA 4, IEC IP67																	
Operating Conditions	Temperature: -25° to +70° C (-22° to +176° F)																	
Weight	RP-LS42F-75L: 0.48 Kg (1.05 lbs.) RP-LS42F-75LE: 0.65 Kg (1.43 lbs.) RP-LS42F-75LF: 0.65 Kg (1.43 lbs.)																	
Certifications	 																	

Rope Pull Emergency Stop Switches – RP-LS42F-75L.. Series

Dimensions

RP-LS42F-75L

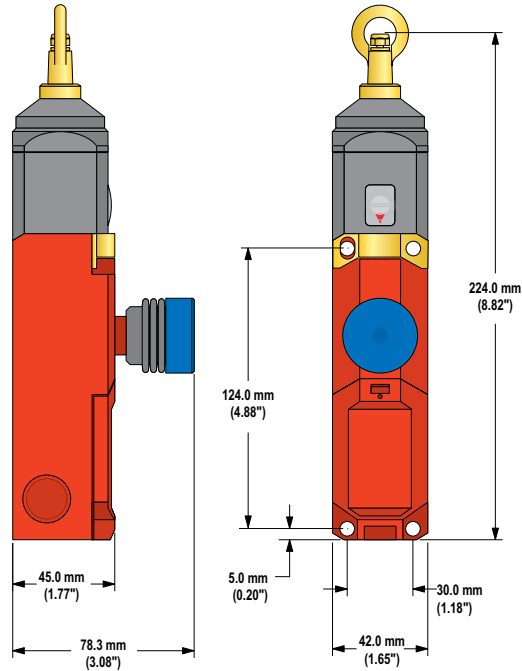

RP-LS42F-75LE

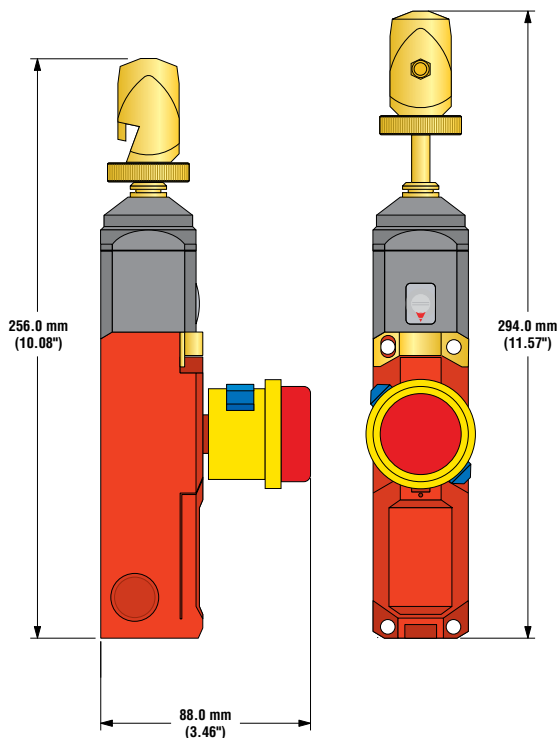

RP-LS42F-75LF

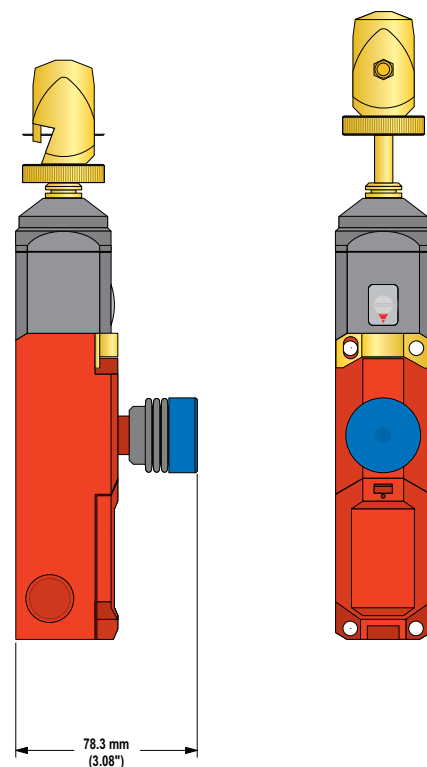

Rope Pull Emergency Stop Switches – RP-LS42F-75L.. Series

Accessories

Components for Wire Rope Assembly

Model	Package Quantity	Description
RPA-C2-10	10 m (33')	3 mm steel wire rope with 0.25 mm red PVC jacket (unterminated)
RPA-C2-20	20 m (66')	
RPA-C2-80	80 m (264')	
RPA-T2-4	4 pcs	Thimble for 3 mm wire rope
RPA-CC2-4	4 pcs	Clamp for 3 mm wire rope
RPA-TA1-1	4 pcs	#4 Turnbuckle
RPA-EB1-1	1 pc	1/4"-20 Eye bolt (3" bolt shaft)
RPA-P1-1	1 pc	Pulley
RPA-S3-1	1 pc	Tensioning spring
RPA-S4-1	1 pc	Tensioning spring with built-in eye bolt, cable thimble, clamping, tensioning, and overload protection

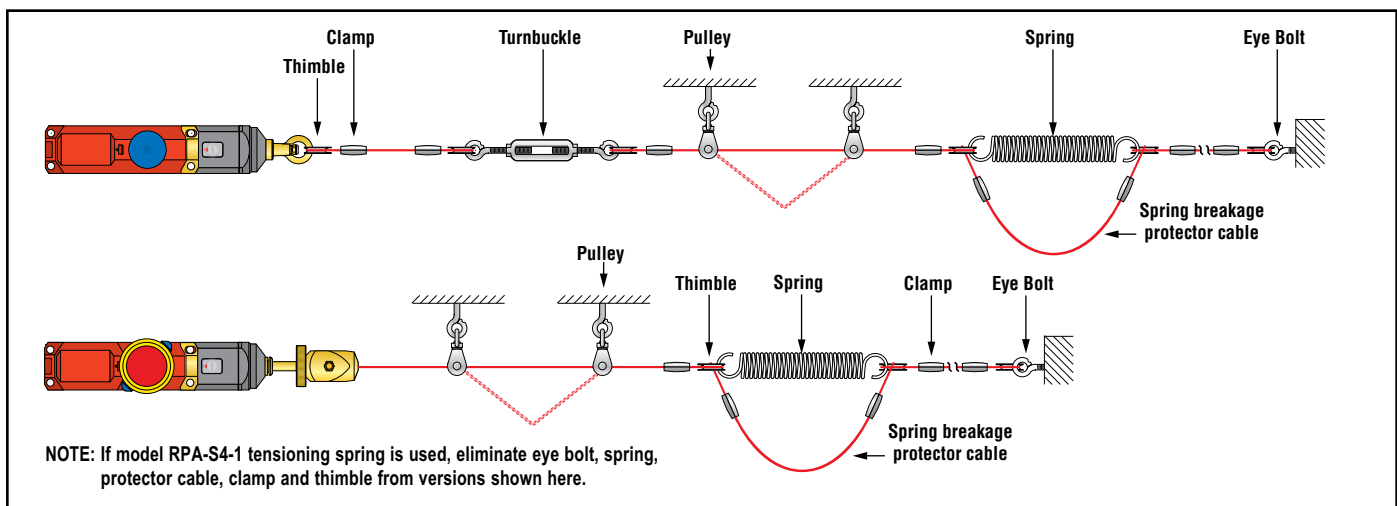
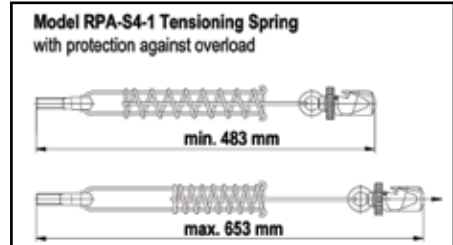
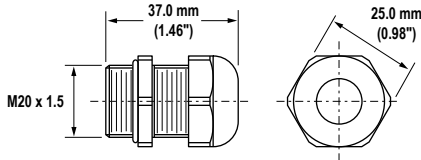
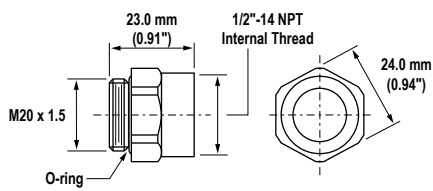

Figure 7. Wire rope assembly components

Rope Pull Emergency Stop Switches – RP-LS42F-75L.. Series

Accessories, continued

Cable Glands				
Size	Model	Used with Switch Models	For Cable Diameters	Dimensions
M20 x 1.5 Plastic	SI-QS-CGM20	All	6.0 to 12.0 mm (0.24" to 0.47")	

Conduit Adaptors				
Size	Model*	Used with Switch Models	Thread Conversion	Dimensions
1/2" -14 NPT Plastic	SI-QS-M20	All	M20 x 1.5 to 1/2" -14 NPT	

*NOTE: One conduit adaptor is supplied with each switch.

Rope Pull Emergency Stop Switches – RP-LS42F-75L.. Series



more sensors, more solutions

WARRANTY: Banner Engineering Corp. warrants its products to be free from defects for one year. Banner Engineering Corp. will repair or replace, free of charge, any product of its manufacture found to be defective at the time it is returned to the factory during the warranty period. This warranty does not cover damage or liability for the improper application of Banner products. This warranty is in lieu of any other warranty either expressed or implied.